

MORNSUN

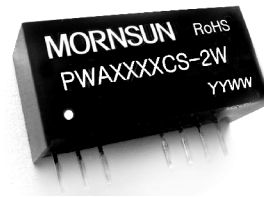

PWA_CS-2W & PWB_CS-2W Series 2W, ULTRAWIDE INPUT, ISOLATED & REGULATED DUAL/SINGLE OUTPUT, DC/DC CONVERTER

RoHS

FEATURES

- High Efficiency up to 81%
- I/O Isolation 1500VDC
- 4:1 wide input range
- Short circuit protection(automatic recovery)
- Operating Temperature: -40°C to +85°C
- Remote ON/OFF control
- Internal SMD construction
- Low Ripple and Noise
- UL94-V0 package
- RoHS Compliance

APPLICATIONS

The PWA_CS-2W & PWB_CS-2W Series are specially designed for applications where a wide range input voltage power supplies are isolated from the input power supply in a distributed power supply system on a circuit board.

These products apply to:

- 1) Where the voltage of the input power supply is wide range (voltage range \leq 4:1);
- 2) Where isolation is necessary between input and output(isolation \leq 1500VDC);
- 3) Where the regulation of the output voltage and the output ripple noise are demanded.

PRODUCT PROGRAM

Part Number	Input			Output			Efficiency (% Typ)
	Voltage (VDC)			Voltage (VDC)	Current (mA)		
	Nominal	Range	Max*		Max	Min	
PWA2405CS-2W	24	9-36	40	±5	±200	±20	76
PWA2409CS-2W				±9	±111	±11	78
PWA2412CS-2W				±12	±83	±8	80
PWA2415CS-2W				±15	±67	±7	79
PWB2403CS-1W6				3.3	500	50	70
PWB2405CS-2W				5	400	40	76
PWB2409CS-2W				9	222	22	78
PWB2412CS-2W				12	167	16	80
PWB2415CS-2W				15	133	13	79
PWA4805CS-2W				48	18-72	80	±5
PWA4809CS-2W	±9	±111	±11				78
PWA4812CS-2W	±12	±83	±8				81
PWA4815CS-2W	±15	±67	±7				80
PWB4803CS-1W6	3.3	500	50				72
PWB4805CS-2W	5	400	40				76
PWB4809CS-2W	9	222	22				78
PWB4812CS-2W	12	167	16				81
PWB4815CS-2W	15	133	13				80

* Input voltage over it may cause permanent damage to the device.

Note: The load shouldn't be less than 10%, otherwise ripple will increase dramatically.

Operation under 10% load will not damage the converter; However, they may not meet all specification listed.

ISOLATION SPECIFICATIONS

Item	Test conditions	Min	Typ	Max	Units
Isolation voltage	Tested for 1 minute and 1 mA max	1500			VDC
Isolation resistance	Test at 500VDC	1000			MΩ
Isolation Capacitance	Input/Output		80		PF

OUTPUT SPECIFICATIONS

Item	Test Conditions	Min	Typ	Max	Units
Output power	See Below Products Program	0.2		2	W
Positive voltage accuracy	Refer To Recommended Circuit		±1	±3	%
Negative voltage accuracy	Refer To Recommended Circuit		±3	±5	
Load regulation	From 10% To 100% Load		±0.5	±1.5*	
Line regulation	Input Voltage From Low To High		±0.2	±0.75	
Temperature drift	Refer To Recommended Circuit			±0.03	%/°C
Ripple& Noise**	20MHz Bandwidth		50	100	mVp-p
Switching frequency	100% Load, Nominal Input Voltage		300		KHz

*Dual output models unbalanced load: ±5%.

**Test ripple and noise by "parallel cable" method. See detailed operation instructions at Testing of Power Converter section, application notes.

Note:

1. All specifications measured at TA=25°C, humidity<75%, nominal input voltage and rated output load unless otherwise specified.
2. See below recommended circuits for more details.

MODEL SELECTION

PWA2405CS-2W

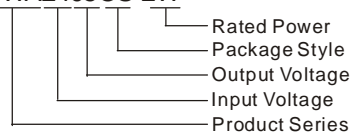

MORNSUN America

43 Broad Street
Hudson, MA 01749
Tel: 978-567-9610
Fax: 978-567-9601
<http://www.mornsunamerica.com>

COMMON SPECIFICATION					
Item	Test Conditions	Min	Typ	Max	Units
Storage humidity				95	%
Operating temperature		-40		85	°C
Storage temperature		-55		125	
Temp. rise at full load			15		
Lead temperature	1.5mm from case for 10 seconds			300	
Cooling		Free air convection			
Short circuit protection		Continuous ,Automatic Recovery			
Case material		Plastic(UL94-V0)			
MTBF		1000			K hours
Weight			5.8		g

TYPICAL TEMPERATURE CURVE

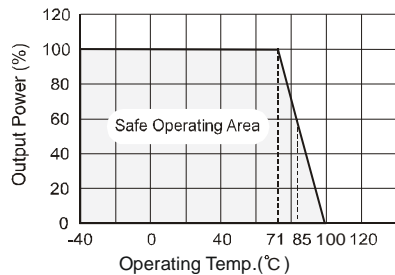

OUTLINE DIMENSIONS & FOOTPRINT DETAILS

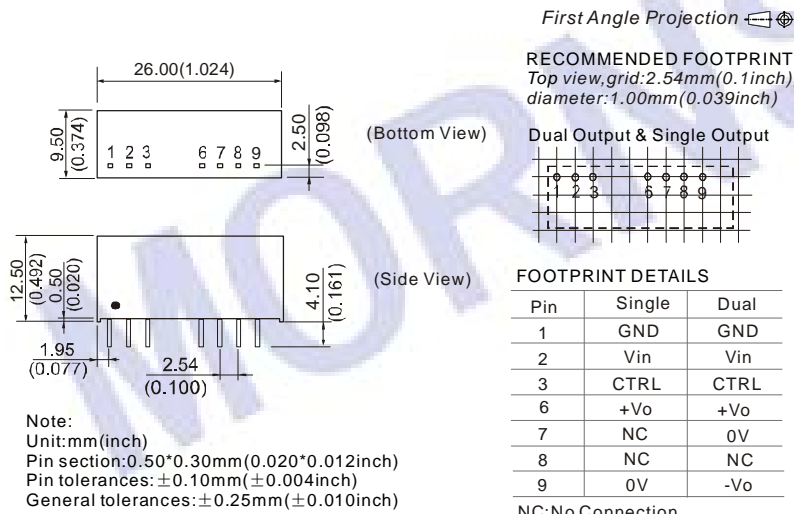

APPLICATION NOTE

Requirement on output load

To ensure this module can operate efficiently and reliably, During operation, the minimum output load is not less than 10% of the full load, and that this product should never be operated under no load! If the actual output power is very small, please connect a resistor with proper resistance at the output end in parallel to increase the load, or use our company's products with a lower rated output power.

TRL Terminal

When open or high impedance, the converter work well; When this pin is 'high'; the converter shutdown; It should be note that the input current should between 5-10mA, exceeding the maximum 20mA will cause permanence damage to the converter. The value of R can be derived as follows:

$$R = \frac{V_c - V_D - 1.0}{I_C}$$

Recommended Circuit

If you want to further decrease the input/output ripple, an "LC" filtering network may be connected to the input and output ends of the DC/DC converter, see (Figure 1).

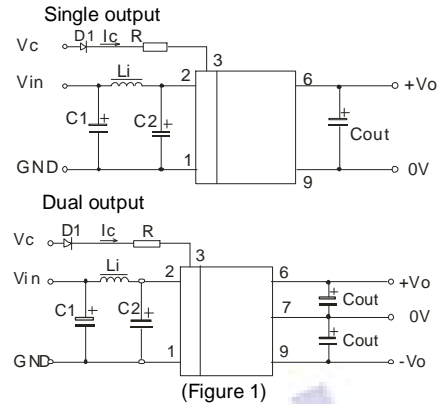

However, the capacitance of the output filter capacitor must be proper. If the capacitance is too big, a startup problem might arise. For every channel of output, provided the safe and reliable operation is ensured, the greatest capacitance of its filter capacitor sees (Table 1). General:

Cin: 10-100uF

Cout: 100uF

Lin: 4.7-120uH

Output External Capacitor Table (Table 1)

Single Vout (VDC)	Cout (uF)	Dual Vout (VDC)	Cou (uF)
3.3	2200	±5	680
5	1000	±9	470
9	680	±12	330
12	470	±15	220
15	220	-	-

Input current

Nominal input voltage range. The input current of the power supply must be sufficient to the startup current (Ip) of the DC/DC module (Figure 2). General: $I_p \leq 1.4 \cdot I_{in-max}$

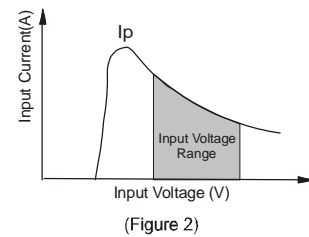

No parallel connection or plug and play.