

## K78XX-500 Series

### WIDE INPUT NON-ISOLATED & REGULATED SINGLE POSITIVE/NEGATIVE OUTPUT

Patent Protection **RoHS**

#### FEATURES

- Efficiency Up To 96%
- Temperature Range: -40°C to +85°C
- No heat sink Required
- Pin-out compatible with LM78XX Linears
- Short circuit protection, Thermal Shutdown
- Low ripple and noise
- SIP Package
- Industry Standard Pinout
- MTBF>2,000,000 hours
- The K78xx-500 Series converters can also be used to convert a positive voltage into a negative voltage.
- Only two extra capacitors are required.
- Input voltage range can be lower than the output voltage for higher output voltages

#### APPLICATIONS

The K78xx-500 Series high efficiency switching regulators are ideally suited to replace 78xx linear regulators and are pin compatible.

#### MODEL SELECTION

K7805-500

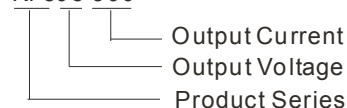

#### MORNSUN America

43 Broad Street  
Hudson, MA 01749  
Tel: 978-567-9610  
Fax: 978-567-9601  
[Http://www.mornsunamerica.com](http://www.mornsunamerica.com)

#### PRODUCT PROGRAM

Part Number	Input	Output		Efficiency(%)	
	Voltage Range (VDC)	Voltage (VDC)	Current (mA)	Vin (Min)	Vin (Max)
K7803-500	4.75-28	3.3	500	90	80
	4.75-25	-3.3	-400	73	78
K7805-500	6.5-32	5.0	500	93	84
	6.0-27	-5.0	-400	78	83
K78X6-500	8-32	6.5	500	94	87
	6.0-25	-6.5	-300	83	85
K7809-500	11-32	9.0	500	95	91
	7.0-23	-9.0	-200	87	86
K7812-500	15-32	12	500	95	92
	7.0-20	-12	-200	85	87
K7815-500	18-32	15	500	96	93
	7.0-17	-15	-200	84	89

#### OUTPUT SPECIFICATIONS

Item	Test Conditions	Min	Typ	Max	Units
Output Voltage accuracy	100% full load		±2	±3	%
Line regulation	Vin= min. to max. at full load		±0.2	±0.4	
Load regulation	10% to 100% load		±0.4	±0.6	
Ripple+Noise*	20MHZ Bandwidth		20	35	mVp-p
Short Circuit Input Power			0.5	1.8	W
Short circuit protection		Continuous, automatic recovery			
Switching frequency		280	330	450	KHz
Quiescent current	Positive Output		5	8	mA
	Negative Output		7	13	
Thermal Shutdown	Internal IC junction		150		°C
Temperature coefficient	-40 °C to +85 °C ambient			0.02	%/°C
Max capacitance load				1000	µF

\*Test ripple and noise by "parallel cable" method.

#### COMMON SPECIFICATION

Item	Test Conditions	Min	Typ	Max	Units
Operating Temp. Range		-40		85	°C
Operating Case Temp.				100	
Storage Temp. Range		-55		125	
Cooling		Free Air Convection			
Case Material		Plastic (UL94-V0)			
Lead Temperature	1.5mm from case for 10 seconds			300	°C
Storage Humidity Range				95	%
MTBF	+25 °C, MIL-HDBK-217F	2000			K hours
Package Weight			2.0		g

Note:

1. All specifications measured at T<sub>A</sub>=25°C, humidity<75%, nominal input voltage and rated output load unless otherwise specified.
2. Only typical models listed. If you need other model, please confirm the power, input voltage and output voltage, then phone us.

## TYPICAL CHARACTERISTICS

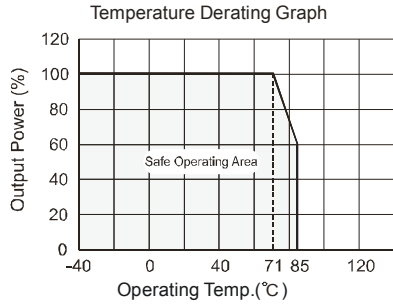

## EXTERNAL CAPACITOR TABLE

Part Number	C1,C3 (ceramic capacitor)	C2,C4 (ceramic capacitor)
K7803-500	10uF/50V	22uF/6.3V
K7805-500	10uF/50V	22uF/10V
K78X6-500	10uF/50V	10uF/10V
K7809-500	10uF/50V	10uF/16V
K7812-500	10uF/50V	10uF/25V
K7815-500	10uF/50V	10uF/25V

## STANDARD APPLICATION CIRCUIT

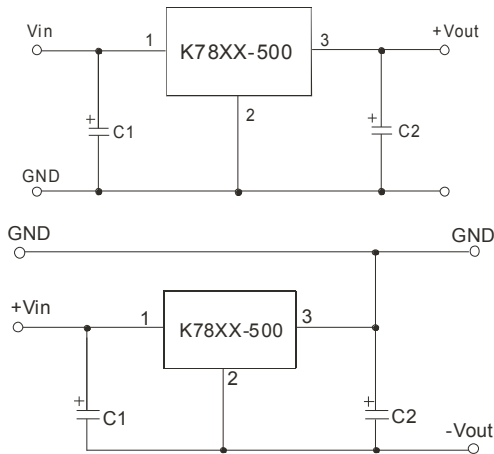

## APPLICATION EXAMPLE

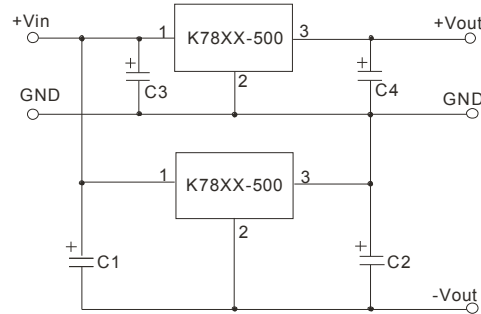

Note:

1. C1 and C2 are required and should be fitted close to the converter pins.
2. The capacitance of C1, C2, C3 and C4 sees external capacitor table, it can be increase properly if required, and tantalum or low ESR electrolytic capacitors may also suffice.
3. No parallel connection or plug and play.

## PACKAGE STYLE AND PINNING

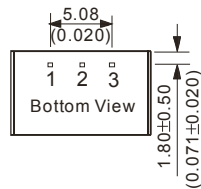
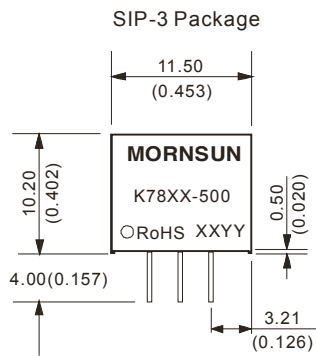

Note:  
Unit:mm(inch)  
Pin section:0.50\*0.30mm(0.020\*0.012inch)  
Pin section tolerances:±0.10mm(±0.004inch)  
General tolerances:±0.25mm(±0.010inch)

First Angle Projection



RECOMMENDED FOOTPRINT  
Top view,grid:2.54mm(0.1inch),  
diameter:1.00mm(0.039inch)

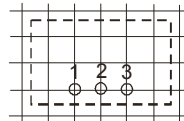

FOOTPRINT DETAILS

Pin	Positive	Negative
1	+Vin	+Vin
2	GND	-Vout
3	+Vout	GND

# CHARACTERISTICS(POSITIVE OUTPUT)

## Efficiency

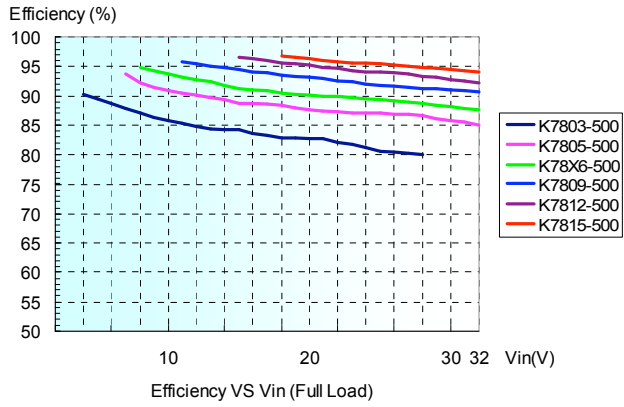

## Ripple

