

RoHS

K78XX-2000(L) Series

WIDE INPUT NON-ISOLATED & REGULATED SINGLE OUTPUT

FEATURES

- Efficiency up to 92%, No heatsink required
- 2A large current output
- Operating temperature : -40°C ~ +85°C
- Short circuit protection, thermal shutdown
- Low ripple and noise
- Micro miniature SIP package, meet UL94-V0 requirement
- Ultra low power loss
- Negative output application
- Industry standard pinout
- Pin-out compatible with LM78XX Linear
- MTBE>2000,000Hours

APPLICATIONS

Upgraded K78xx-2000(L) series switching regulators are ideal replacement for K78xx linear regulators and LDOs. The efficiency of up to 92% means that very little energy is wasted as heat so there is no need for any heat sinks with their additional space and mounting costs. They are widely used in industrial control, instrumentation, and electric power applications.

MODEL SELECTION

K7805-2000

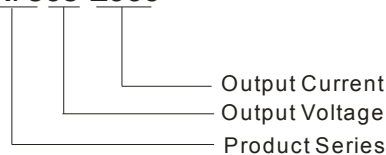

MORNSUN America

Address: 43 Broad Street
Hudson, MA 01749
Tel: 978-567-9610
Fax: 978-567-9601
<http://www.mornsunamerica.com>

PRODUCT PROGRAM

Part Number	Input	Output		Efficiency (%)	
	Voltage Range (VDC)	Voltage (VDC)	Current (mA)	Vin (min.)	Vin (max.)
K7802-2000(L)	4.75-18	2.5	2000	85	83
	6.5-15	-2.5	-1200	81	84
K7803-2000(L)	4.75-18	3.3	2000	87	86
	6.5-16	-3.3	-1200	82	86
K7805-2000(L)	7-18	5	2000	91	88
	7-13	-5	-1000	84	88
K78X6-2000(L)	8.5-18	6.5	2000	92	91
	7-13	-6.5	-800	87	90

Add suffix "L" for 90° bend pins, for example: K7805-2000L.

OUTPUT SPECIFICATIONS

Item	Test conditions	Min.	Typ.	Max.	Units
Output voltage accuracy	100% full load, input voltage range		±2	±3	%
Line regulation	Vin=min. to max, at full load		±0.5	±0.75	
Load regulation	10% to 100% load		±0.5	±1.0	
Ripple & Noise*	20MHZ bandwidth, typical application circuit		25	45	mVp-p
Short circuit input power			0.5	1.8	W
Short circuit protection		Continuous, auto-recovery			
Thermal shutdown			150		°C
Output current limit			5000		mA
Switching frequency	Full load, input voltage range	300	340	380	KHz
Quiescent current	Positive Output		5	10	mA
	Negative Output		11	13	
Temperature coefficient	-40°C ~ +85°C ambient			±0.03	%/°C
Max capacitance load				1000	µF

COMMON SPECIFICATIONS

Operating temp. range	-40~+85 °C	
Operating case temp.	+100 °C(max)	
Storage Temp. range	-55~+125 °C	
Cooling	Free air convection	
Lead temperature**	300 °C(max)	
Storage humidity range	≤ 95%	
Case material	Plastic(UL94-V0)	
MTBF	> 2000kHours	
Package Weight	4.0g	
Conducted emissions(Refer to Figure6)	EN55022	CLASS B
Radiated emissions	EN55022	CLASS B
ESD	EN61000-4-2	CLASS A

**1.5mm from case for 10 seconds

Note: 1. *The Ripple & Noise test circuit please refer to Figure 7

2. All specifications measured at Ta=25°C, humidity<75%, nominal input voltage and rated output load unless otherwise specified.

3. Only typical models listed, other models may be different, please contact our technical person for more details.

TYPICAL CHARECTERISTICS

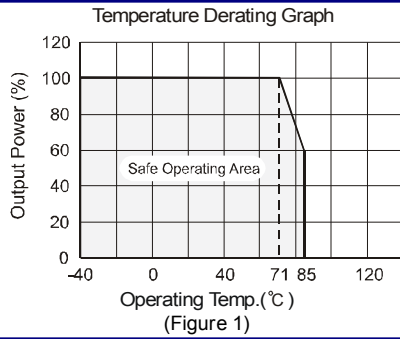

EXTERNAL CAPACITOR TABLE

Part Number	C1 (Ceramic capacitor)	C2 (Ceramic capacitor)
K7802-2000(L)	10 μ F/25V	22 μ F/6.3V
K7803-2000(L)	10 μ F/25V	22 μ F/6.3V
K7805-2000(L)	10 μ F/25V	22 μ F/16V
K78X6-2000(L)	10 μ F/25V	22 μ F/16V

TYPICAL APPLICATION CIRCUIT

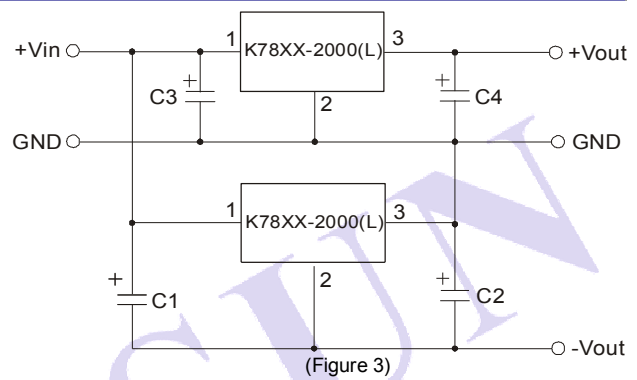
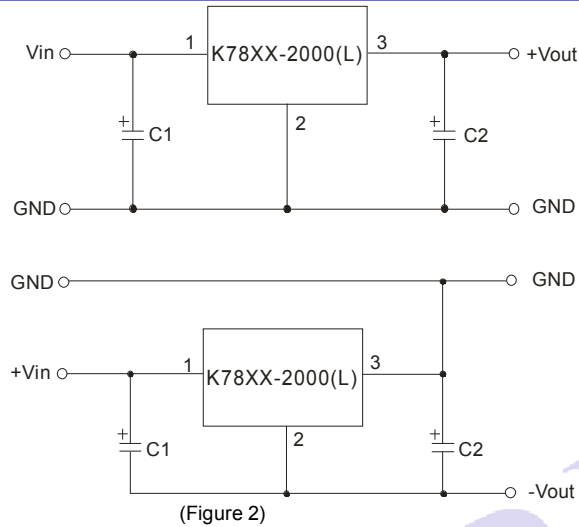

Note:

1. C1 and C2 are required and should be fitted close to the converter pins.
2. The capacitance of C1 and C2 sees external capacitor table, it can be increased properly if required, and tantalum or low ESR electrolytic capacitors may also suffice.
3. No parallel connection or plug and play.

INPUT FILTER CIRCUIT CONNECT

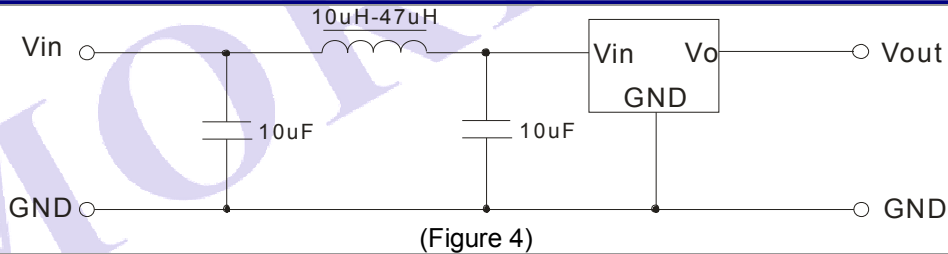

OUTPUT FILTER CIRCUIT CONNECT

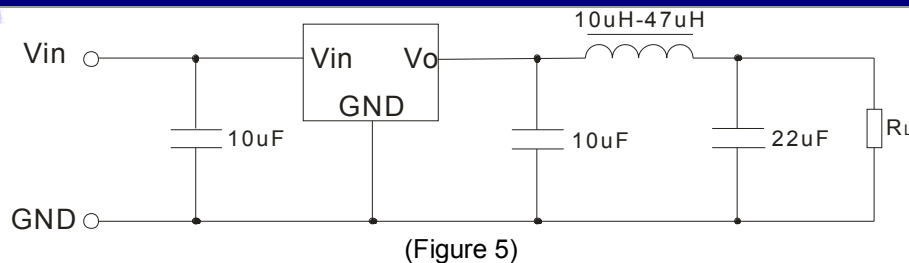

EMC RECOMMENDED CIRCUIT

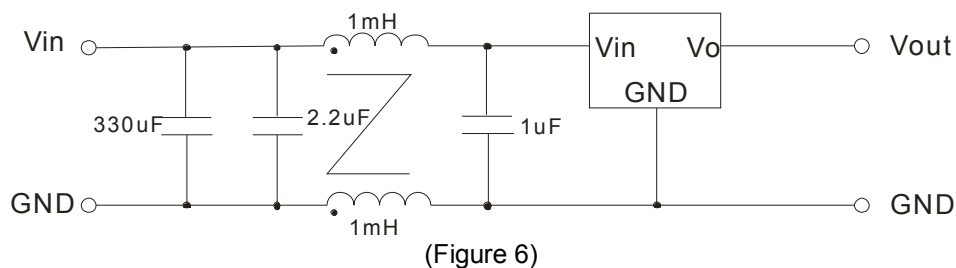

OUTLINE DIMENSIONS & FOOTPRINT DETAILS

MECHANICAL DIMENSIONS

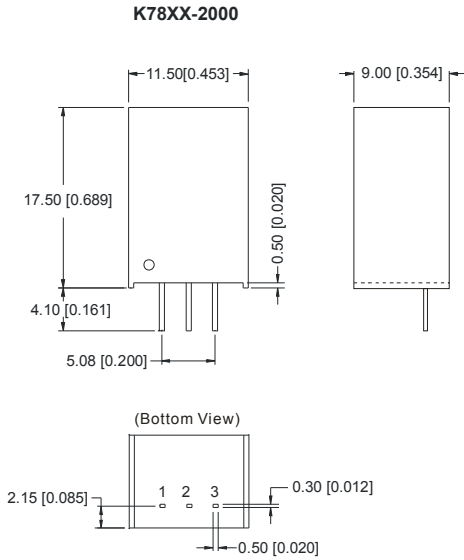

Note:
 Unit:mm[inch]
 Pin section tolerances: $\pm 0.10\text{mm}$ [$\pm 0.004\text{inch}$]
 General tolerances: $\pm 0.25\text{mm}$ [$\pm 0.010\text{inch}$]

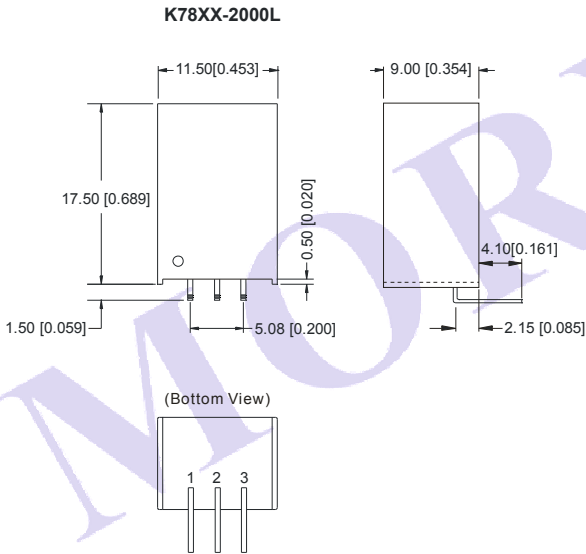

Note:
 Unit:mm[inch]
 Pin section tolerances: $\pm 0.10\text{mm}$ [$\pm 0.004\text{inch}$]
 General tolerances: $\pm 0.50\text{mm}$ [$\pm 0.020\text{inch}$]

RECOMMENDED FOOTPRINT

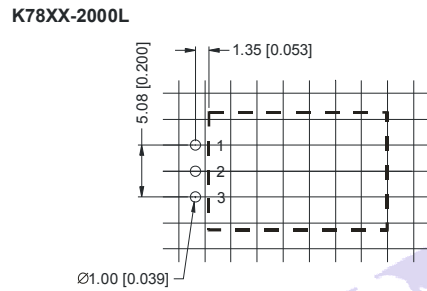
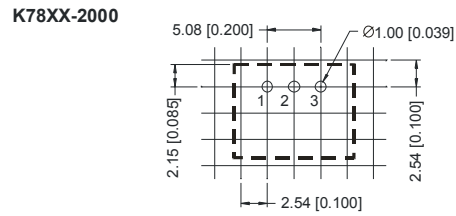

FOOTPRINT DETAILS		
Pin	Positive	Negative
1	+Vin	+Vin
2	GND	-Vout
3	+Vout	GND

TUBE OUTLINE DIMENSIONS

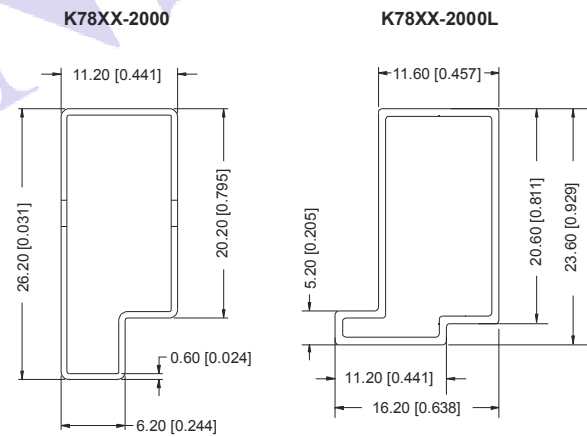

Note:
 Unit :mm[inch]
 General tolerances: $\pm 0.50\text{mm}$ [$\pm 0.020\text{inch}$]
 L=530mm[20.866inch] Devices per tube quantity: 44pcs
 L=220mm[8.661inch] Devices per tube quantity: 17pcs