

MORNSUN

IB_(X)T-1W Series

1W, FIXED INPUT, ISOLATED & REGULATED SINGLE OUTPUT, SMD DC-DC CONVERTER

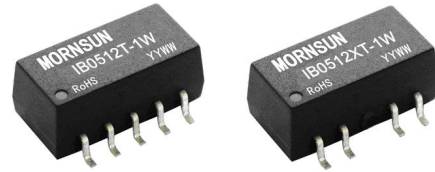

RoHS

FEATURES

- Small footprint
- SMD package style
- 1KVDC isolation
- No heat sink required
- Continuous short circuit protection
- Internal SMD construction
- Temperature range: -40°C to +85°C
- Industry standard pinout
- No external component required
- RoHS Compliance

APPLICATIONS

The IB_(X)T-1W Series are specially designed for applications where a group of polar power supplies are isolated from the input power supply in a distributed power supply system on a circuit board.

These products apply to:

- 1) Where the voltage of the input power supply is fixed (voltage variation $\leq \pm 5\%$);
- 2) Where isolation is necessary between input and output (isolation voltage $\leq 1000\text{VDC}$);
- 3) Where the regulation of the output voltage and the output ripple noise are not demanding.

MODEL SELECTION

IB0512(X)T-1W

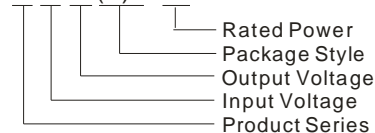

PRODUCT PROGRAM

Part Number	Input		Output			Efficiency (% Typ.)
	Voltage (VDC)		Voltage (VDC)	Current (mA)		
	Nominal	Range		Max.	Min.	
IB0505(X)T-W75	5	4.75-5.25	5	150	15	68
IB0512(X)T-1W			12	83	9	69
IB0515(X)T-1W			15	67	7	69
IB1205(X)T-W75	12	11.4-12.6	5	150	15	68
IB1212(X)T-1W			12	83	9	69
IB1215(X)T-1W			15	67	7	70

Note: 1. IB_XT-1W series designing;
2. IB_XT-1W series have no 3,6,8,9 pin, for example IB0505XT-W75.

COMMON SPECIFICATIONS

Item	Test Conditions	Min.	Typ.	Max.	Units
Storage humidity				95	%
Operating temperature		-40		85	°C
Storage temperature		-55		125	
Temp. rise at full load			15	25	
Lead temperature	1.5mm from case for 10 seconds			260	
Cooling		Free air convection			
Short circuit protection		Continuous			
Package material		Epoxy Resin (UL94-V0)			
MTBF		3500			K hours
Weight			1.70		g

MORNSUN America

Address: 43 Broad Street
Hudson, MA 01749
Tel: 978-567-9610
Fax: 978-567-9610
[Http://www.mornsunamerica.com](http://www.mornsunamerica.com)

ISOLATION SPECIFICATIONS

Item	Test Conditions	Min.	Typ.	Max.	Units
Isolation voltage	Tested for 1 minute and 1mA max	1000			VDC
Isolation resistance	Test at 500VDC	1000			MΩ
Isolation capacitance			40		pF

OUTPUT SPECIFICATIONS

Item	Test Conditions	Min	Typ	Max	Units
Output power		0.1		1	W
Line regulation	For V_{in} change of $\pm 5\%$			± 0.25	%
Load regulation	10% to 100% load			± 1	
Output voltage accuracy	100% full load			± 3	
Temperature drift	100% full load			0.03	%/ $^{\circ}\text{C}$
Ripple*	20MHz Bandwidth		10	20	mVp-p
Noise*	20MHz Bandwidth		50	100	
Switching frequency	Full load, nominal input		100		KHz

*Test ripple and noise by "parallel cable" method. See detailed operation instructions at Testing of Power Converter section, application notes.

TYPICAL CHARACTERISTICS

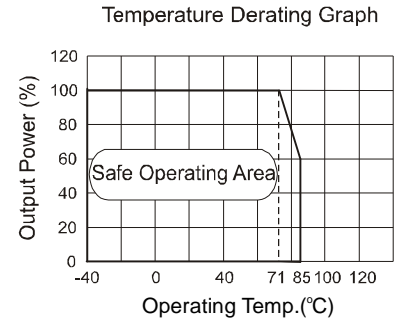

RECOMMENDED REFLOW SOLDERING PROFILE

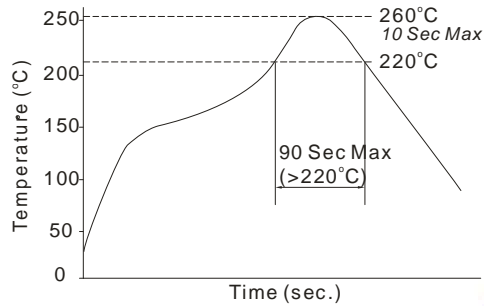

RECOMMENDED CIRCUIT

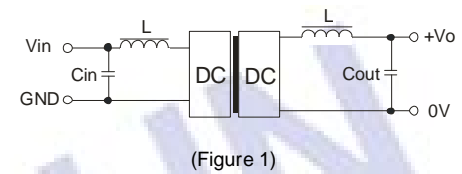

EXTERNAL CAPACITOR TABLE (TABLE 1)

V_{in} (VDC)	C_{in} (μF)	V_{out} (VDC)	C_{out} (μF)
5	4.7	5	4.7
12	2.2	12	1
-	-	15	1

It's not recommended to connect any external capacitor in the application field with less than 0.5 watt output.

APPLICATION NOTE

1) Requirement on output load

To ensure this module can operate efficiently and reliably, During operation, the minimum output load is not less than 10% of the full load, and that this product should **never be operated under no load!** If the actual output power is very small, please connect a resistor with proper resistance at the output end in parallel to increase the load.

2) Recommended testing circuit

If you want to further decrease the input/output ripple, an "LC" filtering network may be connected to the input and output ends of the DC/DC converter, see (Figure 1).

It should also be noted that the inductance and the frequency of the "LC" filtering network should be staggered with the DC/DC frequency to avoid mutual interference. However, the capacitance of the output filter capacitor must be proper. If the capacitance is too big, a startup problem might arise. For every channel of output, provided the safe and reliable operation is ensured, the greatest capacitance of its filter capacitor sees (Table 1).

3) Overload Protection

Under normal operating conditions, the output circuit of these products has no protection against over-current. The simplest method is to connect a self-recovery fuse in series at the input end or add a circuit breaker to the circuit.

4) When the environment temperature is higher than 71°C , the product output power should be less than 60% of the rated power

5) No parallel connection or plug and play

OUTLINE DIMENSIONS & FOOTPRINT DETAILS

MECHANICAL DIMENSIONS

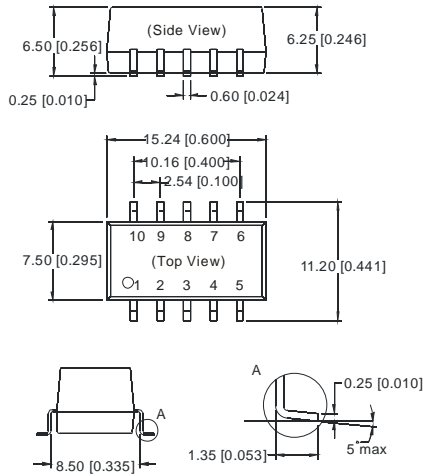

Note:
 Unit: mm[inch]
 Pin section tolerances: $\pm 0.10\text{mm} [\pm 0.039\text{inch}]$
 General tolerances: $\pm 0.15\text{mm} [\pm 0.006\text{inch}]$

TUBE OUTLINE DIMENSIONS

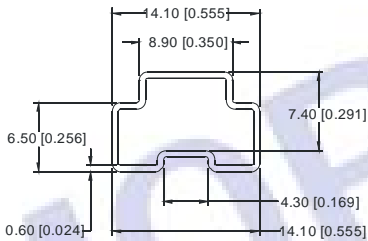

Note:
 Unit: mm[inch]
 General tolerances: $\pm 0.5\text{mm} [\pm 0.020\text{inch}]$
 L=530mm[20.866inch] Tube Quantity: 33pcs
 L=220mm[8.661inch] Tube Quantity: 12pcs

RECOMMENDED FOOTPRINT

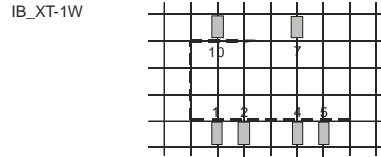
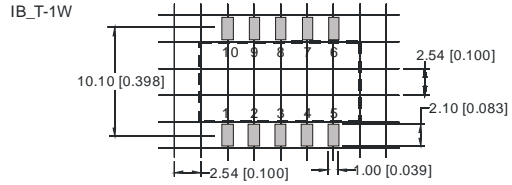

FOOTPRINT DETAILS		
Pin	Function(T)	Function(XT)
1	GND	GND
2	Vin	Vin
4	0V	0V
5	-Vo	-Vo
7	+Vo	+Vo
10	NC	NC
3, 6, 8, 9	NC	No Pin

NC: No Connection

REEL PACKING OUTLINE DIMENSIONS

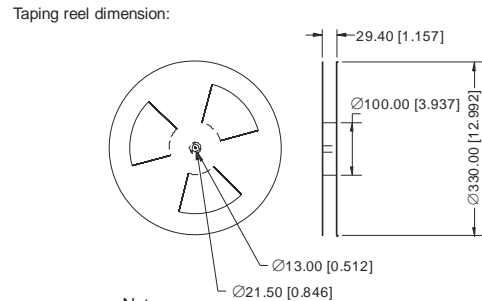
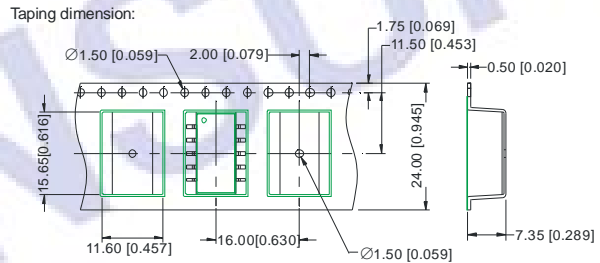

Note:
 Unit: mm[inch]
 General tolerances: $\pm 0.5\text{mm} [\pm 0.020\text{inch}]$
 Devices per reel quantity: 500pcs

Note:

1. Operation under minimum load will not damage the converter; However, they may not meet all specification listed.
2. All specifications measured at $T_a=25^\circ\text{C}$, humidity<75%, nominal input voltage and rated output load unless otherwise specified.
3. In this datasheet, all the test methods of indications are based on corporate standards.
4. Only typical models listed, other models may be different, please contact our technical person for more details.