



Continuous Short
Circuit Protection

E_S-1WR & F_S-1WR Series

1W, FIXED INPUT, ISOLATED & UNREGULATED
DUAL/SINGLE OUTPUT DC-DC CONVERTER



Patent Protection RoHS

FEATURES

- SIP Package
- Output Short Circuit Protection
- Low Isolation Capacitance
- 3000VDC Isolation Voltage
- Operating Temperature: -40°C ~ +85°C
- No External Component Required
- Internal SMD construction
- Industry Standard Pinout
- RoHS Compliance

APPLICATIONS

The E_S-1WR & F_S-1WR Series are specially designed for applications where a group of polar power supplies are isolated from the input power supply in a distributed power supply system on a circuit board.

These products apply to:

- 1) Where the voltage of the input power supply is fixed (voltage variation $\leq \pm 10\%$);
- 2) Where isolation is necessary between input and output (isolation voltage $\leq 3000\text{VDC}$);
- 3) Where the regulation of the output voltage and the output ripple noise are not demanding.

Such as: purely digital circuits, ordinary low frequency analog circuits, and IGBT power device driving circuits.

MODEL SELECTION

F0505S-1WR

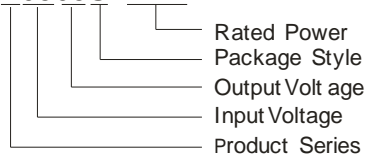

MORNSUN America

43 Broad Street
Hudson, MA 01749
Tel: 978-567-9610
Fax: 978-567-9601
<http://www.mornsunamerica.com>

PRODUCT PROGRAM

Part Number	Input		Output			Efficiency (%) (Typ.)
	Voltage (VDC)		Voltage (VDC)	Current (mA)		
	Nominal	Range		Max	Min	
E0515S-1WR	5	4.5-5.5	± 15	± 34	± 3	75
F0505S-1WR			5	200	20	73
F2405S-1WR	24	21.6-26.4	5	200	20	70

*The other input voltage or output voltage models please consult our sellers.

COMMON SPECIFICATIONS

Item	Test conditions	Min	Typ	Max	Units
Storage humidity				95	%
Operating Temperature		-40		85	°C
Storage Temperature		-55		125	
Temp. rise at full load			20	30	
Lead temperature	1.5mm from case for 10 seconds			300	
Cooling		Free air convection			
Case material		Plastic (UL94-V0)			
Short circuit protection*		Sustainable protection, Automatic recovery			
MTBF		1940			K hours
Weight			2.3		g

OUTPUT SPECIFICATIONS

Item	Test conditions	Min.	Typ.	Max.	Units
Output power		0.1		1	W
Line regulation	For V_{in} change of $\pm 1\%$		± 1.1	± 1.5	%
Load regulation	10% to 100% load			20	
Output voltage accuracy		Follow the tolerance envelope graph			
Temperature drift	100% full load			± 0.03	%/°C
Ripple & Noise*	20MHz Bandwidth		100	200	mVp-p
Switching frequency	Full load, nominal input		100		kHz

*Test ripple and noise by "parallel cable" method. See detailed operation instructions at Testing of Power Converter section, application notes

ISOLATION SPECIFICATIONS

Item	Test conditions	Min	Typ	Max	Units
Isolation voltage	Tested for 1 minute and 1 mA max	3000			VDC
Isolation resistance	Test at 500VDC	1000			MΩ
Isolation Capacitance			6	15	PF

TYPICAL CHARACTERISTICS

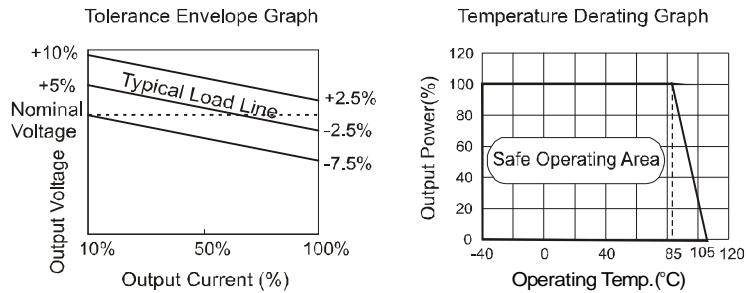

APPLICATION NOTE

① Requirement on output load

To ensure this module can operate efficiently and reliably, During operation, the minimum output load is **not less than 10%** of the full load, and that **this product should never be operated under no load!** If the actual output power is very small, please connect a resistor with resistance of 10% rated power at the output end in parallel, or use our company's products with a lower rated output power

② Overload Protection

Under normal operating conditions, the output circuit of these products has no protection against overload. The simplest method is to connect a slow-blow fuse in series at the input end or add a circuit breaker to the circuit.

③ Recommended testing and application circuit

If you want to further decrease the input ripple or the input inrush current, an "LC" filtering network may be connected to the input and output ends of the DC/DC converter, see (Figure 1).

It should also be noted that the inductance and the frequency of the "LC" filtering network should be staggered with the DC/DC frequency to avoid mutual interference. However, the capacitance of the output filter capacitor must be proper. If the capacitance is too big, a startup problem might arise. For every channel of output, provided the safe and reliable operation is ensured, the recommended capacitance of its filter capacitor sees (Table 1).

④ Output Voltage Regulation and Over-voltage Protection Circuit

The simplest device for output voltage regulation, over-voltage and over-current protection is a linear voltage regulator with overheat protection that is connected to the input or output end in series (Figure 2).

⑤ No parallel connection or plug and play

RECOMMENDED CIRCUIT

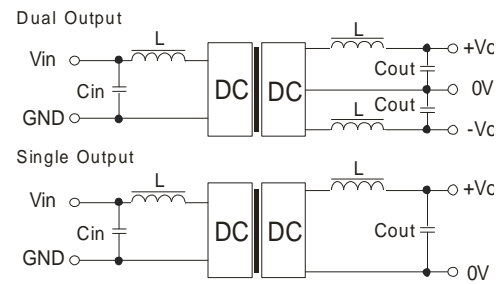

(Figure 1)

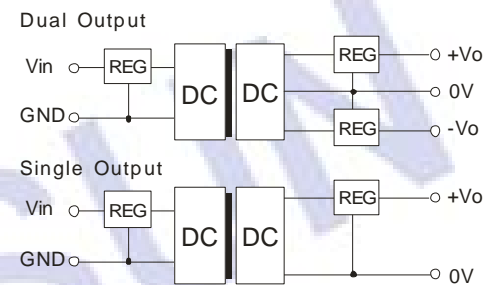

(Figure 2)

Recommended capacitance(Table 1)

Vin (VDC)	Cin (uF)	Single output (VDC)	Cout (uF)	Dual output (VDC)	Cout (uF)
5	4.7	5	10	±5	4.7
12	2.2	9	4.7	±9	2.2
15	2.2	12	2.2	±12	1
24	1	15	1	±15	0.47

1. The recommended external capacitance please use the ceramic capacitor;
2. For applications where output power is less than 0.5W in reality, external capacitors are not recommended.

OUTLINE DIMENSIONS & PIN CONNECTIONS

MECHANICAL DIMENSIONS

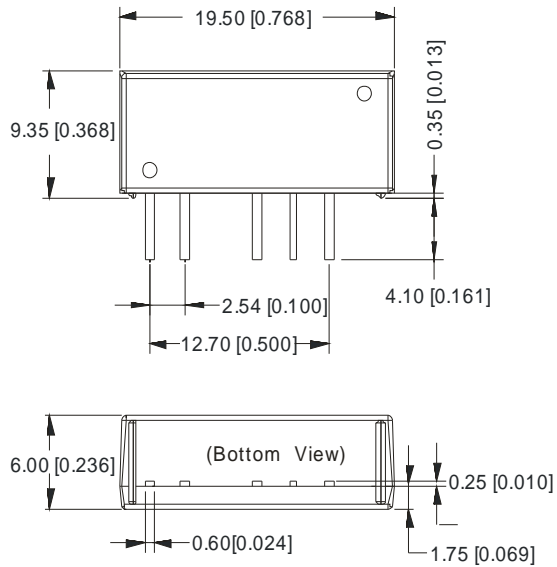

Note:
 Unit: mm[inch]
 Pinsection tolerances: $\pm 0.10\text{mm}[\pm 0.004\text{inch}]$
 General tolerances: $\pm 0.25\text{mm}[\pm 0.010\text{inch}]$

FOOTPRINT DETAILS		
PIN	E_S-1WR	F_S-1WR
1	Vin	Vin
2	GND	GND
4	-Vo	0V
5	0V	No Pin
6	+Vo	+Vo

RECOMMENDED FOOTPRINT

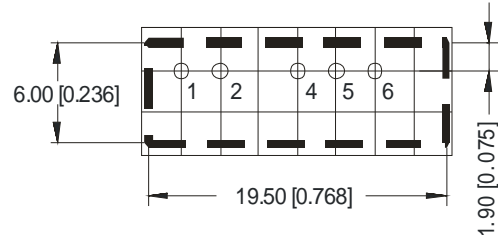

TUBE OUTLINE DIMENSIONS

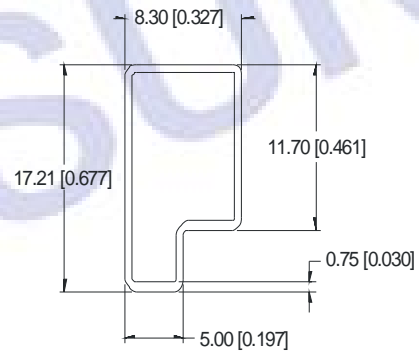

Note:
 Unit: mm[inch]
 General tolerances: $\pm 0.50\text{mm}[\pm 0.020\text{inch}]$

L=530mm[20.866inch] pcs/tube : 25
 L=220mm[8.661inch] pcs/tube: 10

Note:

1. Operation under minimum load will not damage the converter; However, they may not meet all specification listed.
2. All specifications measured at $T_a=25^\circ\text{C}$, humidity<75%, nominal input voltage and rated output load unless otherwise specified.
3. In this datasheet, all the test methods of indications are based on corporate standards.
4. Only typical models listed, other models may be different, please contact our technical person for more details.