

MORNSUN

B_(X)T-1W Series

**1W, FIXED INPUT, ISOLATED & UNREGULATED
SINGLE OUTPUT DC-DC CONVERTER
ULTRAMINIATURE SMD PACKAGE**

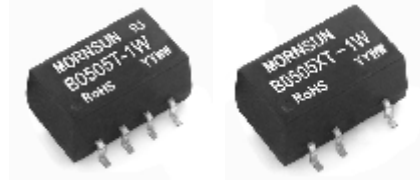

FEATURES

- Small Footprint
- SMD Package Style
- 1KVDC Isolation
- Temperature Range: -40°C ~ +85°C
- Industry Standard Pinout
- No Heatsink Required
- High Power Density
- Internal SMD construction
- No External Component Required
- RoHS Compliance

APPLICATIONS

The B_(X)T-1W series are specially designed for applications where a group of polar power supplies are isolated from the input power supply in a distributed power supply system on a circuit board. These products apply to:

- 1) Where the voltage of the input power supply is fixed (voltage variation $\leq \pm 10\%$);
- 2) Where isolation is necessary between input and output (isolation voltage $\leq 1000\text{VDC}$);
- 3) Where the regulation of the output voltage and the output ripple noise are not demanding.

Such as: purely digital circuits, ordinary low frequency analog circuits, and IGBT power device driving circuits.

MODEL SELECTION

B0505(X)T-1W

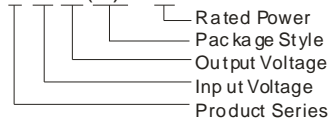

MORNSUN America

43 Broad Street
Hudson, MA 01749
Tel: 978-567-9610
Fax: 978-567-9601
[Http://www.mornsunamerica.com.com](http://www.mornsunamerica.com.com)

PRODUCT PROGRAM

| Part Number | Input | | Output | | | Efficiency (% Typ.) | Certificate |
|--------------|---------------|-----------|---------------|--------------|------|---------------------|-------------|
| | Voltage (VDC) | | Voltage (VDC) | Current (mA) | | | |
| | Nominal | Range | | Max. | Min. | | |
| B0303(X)T-1W | 3.3 | 3.0-3.6 | 3.3 | 303 | 30 | 73 | UL |
| B0305(X)T-1W | | | 5 | 200 | 20 | 74 | UL |
| B0503(X)T-1W | 5 | 4.5-5.5 | 3.3 | 303 | 30 | 72 | |
| B0505(X)T-1W | | | 5 | 200 | 20 | 77 | UL CE |
| B0509(X)T-1W | | | 9 | 111 | 12 | 76 | UL CE |
| B0512(X)T-1W | | | 12 | 84 | 9 | 79 | UL CE |
| B0515(X)T-1W | | | 15 | 67 | 7 | 78 | UL CE |
| B1205(X)T-1W | 12 | 10.8-13.2 | 5 | 200 | 20 | 69 | UL CE |
| B1209(X)T-1W | | | 9 | 111 | 12 | 73 | UL CE |
| B1212(X)T-1W | | | 12 | 84 | 9 | 73 | UL CE |
| B1215(X)T-1W | | | 15 | 67 | 7 | 74 | UL CE |
| B2403(X)T-1W | 24 | 21.6-26.4 | 3.3 | 300 | 30 | 69 | |
| B2405(X)T-1W | | | 5 | 200 | 20 | 70 | |
| B2409(X)T-1W | | | 9 | 110 | 11 | 72 | |
| B2412(X)T-1W | | | 12 | 83 | 8 | 75 | |
| B2415(X)T-1W | | | 15 | 67 | 7 | 76 | |
| B2424(X)T-1W | | | 24 | 42 | 4 | 77 | |

Note: 1. The B_XT-1W series have no 3,6,7 pin, For example B0505XT-1W.
2. B_XT-1W series: UL-60950-1 pending.

COMMON SPECIFICATIONS

| Item | Test Conditions | Min. | Typ. | Max. | Units |
|---------------------------|--------------------------------|-----------------------|------|------|---------|
| Storage humidity | | | | 95 | % |
| Operating temperature | | -40 | | 85 | °C |
| Storage temperature | | -55 | | 125 | |
| Temp. rise at full load | | | 15 | 25 | |
| Lead temperature | 1.5mm from case for 10 seconds | | | 260 | |
| Cooling | | Free air convection | | | |
| package material | | Epoxy Resin (UL94-V0) | | | |
| Short circuit protection* | | | | 1 | s |
| MTBF | | 3500 | | | k hours |
| Weight | | | 1.41 | | g |

*Supply voltage must be discontinued at the end of short circuit duration.

ISOLATION SPECIFICATIONS

| Item | Test Conditions | Min. | Typ. | Max. | Units |
|----------------------|---------------------------------|------|------|------|-------|
| Isolation voltage | Tested for 1 minute and 1mA max | 1000 | | | VDC |
| Isolation resistance | Test at 500VDC | 1000 | | | MΩ |

| OUTPUT SPECIFICATIONS | | | | | | |
|-------------------------|-----------------------------------|-----------------|------------------------------|------|-------|-------|
| Item | Test Conditions | | Min | Typ. | Max | Units |
| Output power | | | 0.1 | | 1 | W |
| Line regulation | For Vin change of ±1% | (3.3V output) | | | ±1.5 | % |
| | | (Others output) | | | ±1.2 | |
| Load regulation | 10%to100% load (3.3V output) | | | 15 | 20 | % |
| | 10%to100% load (5V output) | | | 12.8 | 15 | |
| | 10%to100% load (9V output) | | | 8.3 | 10 | |
| | 10%to100% load (12V output) | | | 6.8 | 10 | |
| | 10%to100% load (15V output) | | | 6.3 | 10 | |
| | 10%to100% load (24V output) | | | 5 | 10 | |
| Output voltage accuracy | | | See tolerance envelope graph | | | |
| Temperature drift | 100% full load | | | | ±0.03 | %/°C |
| Output ripple & Noise* | 20MHz Bandwidth | | | 50 | 75 | mVp-p |
| Switching frequency | Full load, nominal input (5V/12V) | | | 100 | | kHz |
| | Full load, nominal input (24V) | | | 500 | | |

*Test ripple and noise by "parallel cable" method. See detailed operation instructions at Testing of Power Converter section, application notes.

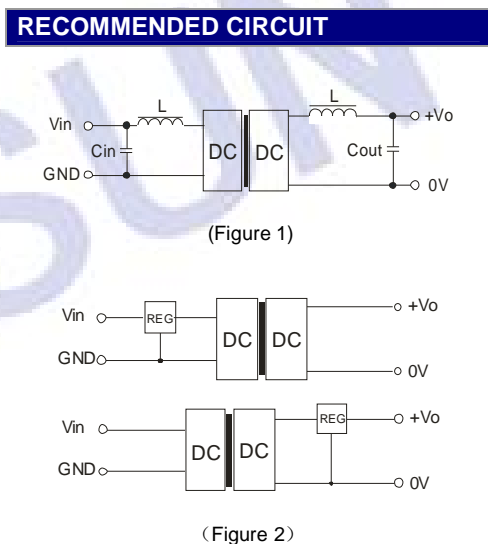
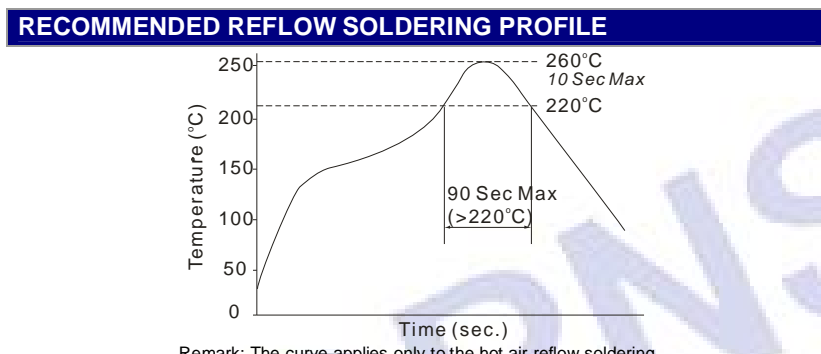
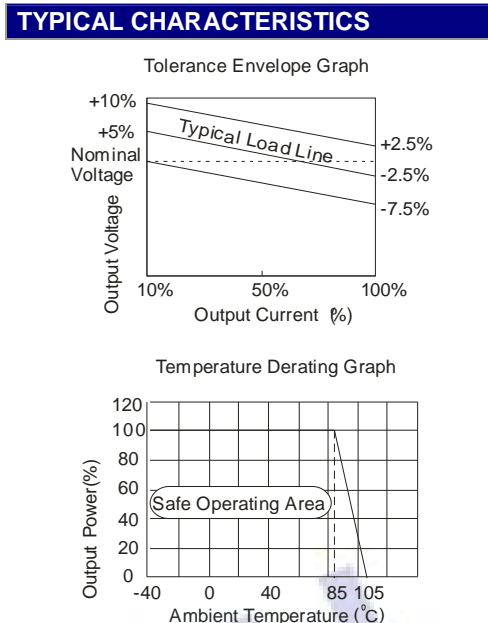

APPLICATION NOTE

1) Requirement on output load
 To ensure this module can operate efficiently and reliably, During operation, the minimum output load is **not less than 10%** of the full load, and that this product should **never be operated under no load!** If the actual output power is very small, please connect a resistor with proper resistance at the output end in parallel to increase the load, or use our company's products with a lower rated output power (B_(X)T-W2 series).

2) Recommended testing circuit
 If you want to further decrease the input/output ripple, an "LC" filtering network may be connected to the input and output ends of the DC/DC converter, see (Figure1).
 It should also be noted that the inductance and the frequency of the "LC" filtering network should be staggered with the DC/DC frequency to avoid mutual interference. However, the capacitance of the output filter capacitor must be proper. If the capacitance is too big, a startup problem might arise. For every channel of output, provided the safe and reliable operation is ensured, the greatest capacitance of its filter capacitor sees (Table 1).

EXTERNAL CAPACITOR TABLE (TABLE 1)

| Vin (VDC) | Cin (μF) | Single Vout (VDC) | Cout (μF) |
|-----------|----------|-------------------|-----------|
| 3.3/5 | 4.7 | 3.3/5 | 10 |
| 12 | 2.2 | 9 | 4.7 |
| 24 | 0.47 | 12 | 2.2 |
| - | - | 15 | 1 |
| - | - | 24 | 0.47 |

It's not recommended to connect any external capacitor in the application field with less than 0.5 watt output.

3) Output Voltage Regulation and Over-voltage Protection Circuit
 The simplest device for output voltage regulation, over-voltage and over-current protection is a linear voltage regulator with overheat protection that is connected to the input or output end in series (Figure2).

4) Overload Protection
 Under normal operating conditions, the output circuit of these products has no protection against overload. The simplest method is to connect a self-recovery fuse in series at the input end or add a circuit breaker to the circuit.

5) No parallel connection or plug and play

OUTLINE DIMENSIONS & FOOTPRINT DETAILS

MECHANICAL DIMENSIONS

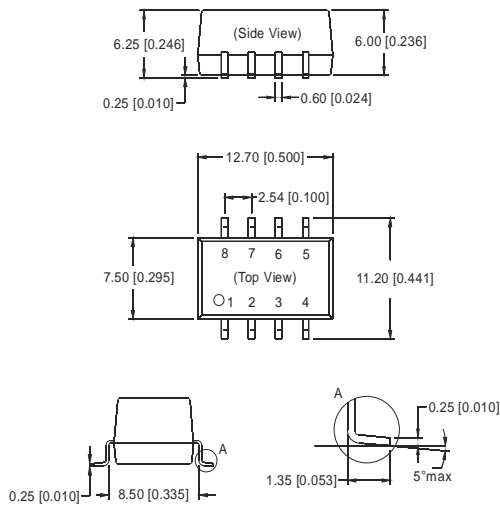

Note:
 Unit: mm[inch]
 Pin section tolerances: $\pm 0.10\text{mm}[\pm 0.004\text{inch}]$
 General tolerances: $\pm 0.25\text{mm}[\pm 0.010\text{inch}]$

RECOMMENDED FOOTPRINT

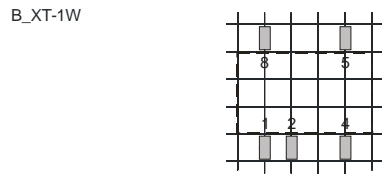
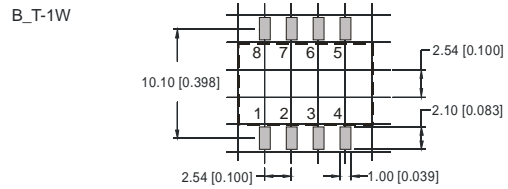

| FOOTPRINT DETAILS | | |
|-------------------|--------|---------|
| Pin | B_T-1W | B_XT-1W |
| 1 | GND | GND |
| 2 | Vin | Vin |
| 4 | 0V | 0V |
| 5 | +Vo | +Vo |
| 3,6,7 | NC | No Pin |
| 8 | NC | NC |

NC: No Connection

TUBE OUTLINE DIMENSIONS

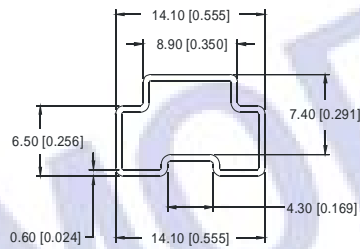

Note:
 Unit: mm[inch]
 General tolerances: $\pm 0.5\text{mm}[\pm 0.020\text{inch}]$
 L=540mm[21.260inch] Devices per tube quantity: 40pcs
 L=220mm[8.661inch] Devices per tube quantity: 15pcs

REEL PACKING OUTLINE DIMENSIONS

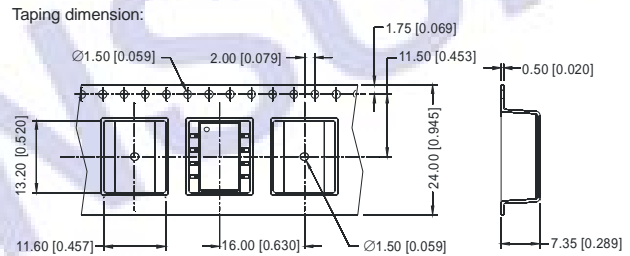

Taping reel dimension:

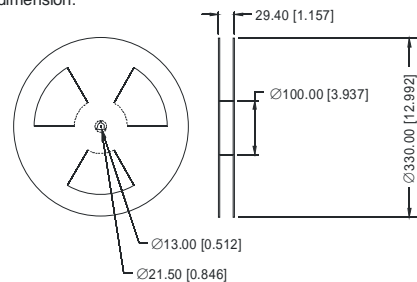

Note:
 Unit: mm[inch]
 General tolerances: $\pm 0.5\text{mm}[\pm 0.020\text{inch}]$
 Devices per reel quantity: 500pcs

Note:

1. Operation under minimum load will not damage the converter; However, they may not meet all specification listed.
2. All specifications measured at $T_a=25^\circ\text{C}$, humidity<75%, nominal input voltage and rated output load unless otherwise specified.
3. Only typical models listed, other models may be different, please contact our technical person for more details.
4. In this datasheet, all the test methods of indications are based on corporate standards.